

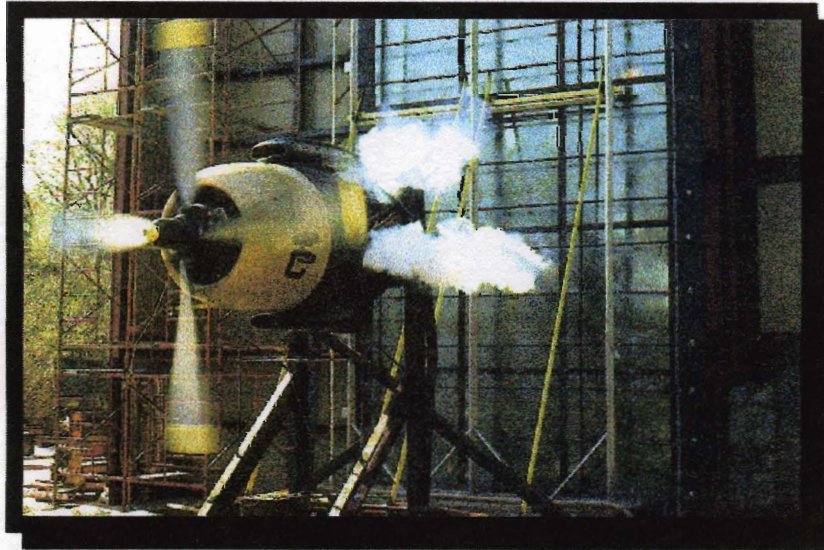

CONSTRUCTION CONSULTING LABORATORY, *INTERNATIONAL*



---

**TEST REPORT:**

**ASTM E 1996-1886 Performance Testing  
Simpson Door Company  
Series 7001 Wood French Fixed  
REPORT #CCLI-05-128**

**September 19, 2005**

---

Prepared for:

**Simpson Door Company**  
400 Simpson Ave  
McCleary, WA 98557

1601 Luna Road  
Carrollton, Texas 75006

**S-UNITED, INC.**  
*A Quality Control Company*

Office: (972) 242-0556  
FAX: (972) 245-6047



ASTM E 1996-1886 PERFORMANCE TESTING  
SIMPSON DOOR COMPANY  
SERIES 7001 WOOD FRENCH FIXED  
REPORT #CCLI-05-128

September 19, 2005

## TABLE OF CONTENTS

1. PROJECT DATA.....	1
2. INTRODUCTION.....	1
3. SUMMARY.....	1
4. IMPACT ACCEPTANCE CRITERIA .....	2
5. TEST SPECIMEN .....	2
6. DESCRIPTION.....	2
7. PERFORMANCE RESULTS.....	3
8. CONCLUSION .....	5

### APPENDIXES

APPENDIX A: SIMPSON DOOR COMPANY 7001 WOOD FRENCH FIXED PRODUCT DRAWINGS



ASTM E 1996-1886 PERFORMANCE TESTING  
**SIMPSON DOOR COMPANY**  
**SERIES 7001 WOOD FRENCH FIXED**  
 REPORT #CCLI-05-128

September 19, 2005  
 Page 1 of 5

**1. PROJECT DATA**

**Project:** ASTM E 1996-1886 Performance Testing

**Date(s) of Testing:** July 18, 2005

**Tested For:** Simpson Door Company  
 400 Simpson Ave Phone: (360) 495-3291  
 McCleary, WA 98557 Fax: (360) 495-2088

**Testing Performed At:** Construction Consulting Laboratory, *International*  
 Carrollton, Texas

**Witnessed By:** (All or Partial Viewing)

John Quist Simpson Door Company

Brandon Newman Construction Consulting Laboratory, *International*  
 Jeffrey Crump Construction Consulting Laboratory, *International*

**2. INTRODUCTION**

This report presents the performance characteristics of a Simpson Door Company. Series 7001 Wood French Fixed. Tests were conducted at Construction Consulting Laboratory, *International* (CCLI) testing facility in Carrollton, TX.

**3. SUMMARY**

Simpson Door Company 7001 Wood French Fixed was tested in accordance with AAMA 506-2000 and achieved a design 60 rating. The impact resistant series was also impacted with a large nominal 2x4 #2 yellow pine projectile weighing 9 lbs and measuring 8'-0". This missile size and weight complies with the Type D requirements of ASTM E 1996-03 and the Type C requirements of ASTM E 1996-97. At the completion of impacts, the test specimen was Uniform Load cycled at a Design 60.0 psf test pressure in accordance with ASTM E 1886-04.

Florida Registered Professional Engineers Review: Reg. # 52849, February 28, 2007

Signature: \_\_\_\_\_

*Abdol Rezaad 9/26/05*

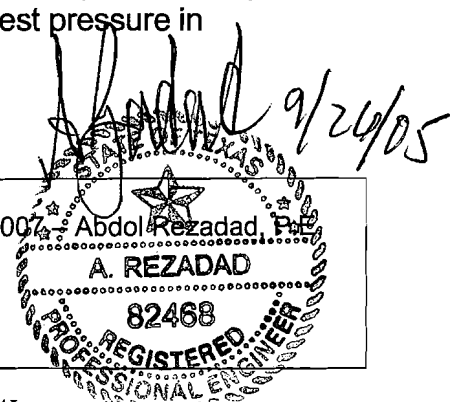



ASTM E 1996-1886 PERFORMANCE TESTING  
**SIMPSON DOOR COMPANY**  
**SERIES 7001 WOOD FRENCH FIXED**  
 REPORT #CCLI-05-128

September 19, 2005  
Page 2 of 5

**4. IMPACT ACCEPTANCE CRITERIA**

The test specimen shall resist the large missile impact with no tear formed longer than 5" (130 mm) or no opening formed through which a 3" (76 mm) solid sphere can freely pass when evaluated during and upon completion of missile impacts and test loading program.

**5. TEST SPECIMEN**

**Product Type:** Wood French Fixed **Product Drawings, Appendix A**  
**Series Model:** Simpson Door Company Wood French Fixed  
**Specifications:** AAMA 506-2000 (1996-03 Type D/1996-97 Type C)  
**Design:** DP-60.00  
**Frame Size:** 3'-1<sup>1</sup>/<sub>4</sub>" x 8'-1<sup>1</sup>/<sub>2</sub>" (37.250" x 97.500")  
**Fixed Panel Size:** 3'-0" x 8'-0" (36" x 96")  
**Frame Dimension:** 4.632"  
**Door Thickness:** 1.715"  
**Configuration:** O

Refer to Mock-Up drawings in **Appendix A**. This report is not complete unless this laboratory symbol is stamped and initialed onto the drawings.

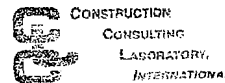

1601 Luna Road  
Carrollton, Texas 75006

Phone (972) 242-0546  
 Report# 05-128 Date 9/19/05  
 Reviewed BY [Signature]

**6. DESCRIPTION**

**Weather Strip:** None.

**Hardware:** None.

**Cardinal I.G. Impact Resistant Sealed Insulated Glass:** Laminated interior lite, interior side is 1/8" annealed, SentryGlas 0.090" interlayer, and 1/8" annealed, 1/2" aluminum air spacer, exterior side is 1/8" fully tempered. Glass thickness is 3/4" overall.

Florida Registered Professional Engineers Review: Reg. # 52849, February 28, 2007

Signature: [Signature] 9/26/05

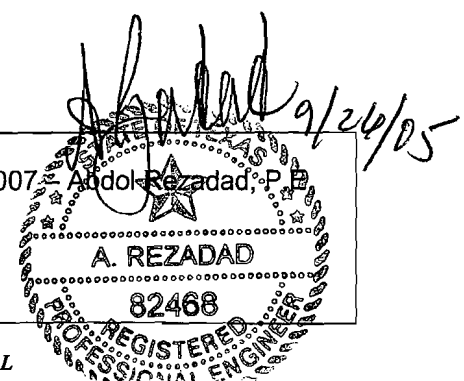



ASTM E 1996-1886 PERFORMANCE TESTING  
**SIMPSON DOOR COMPANY**  
**SERIES 7001 WOOD FRENCH FIXED**  
 REPORT #CCLI-05-128

September 19, 2005  
 Page 3 of 5

**Impact Resistant Glazing:** Interior glazed with Schnee Moorehead SM2100 Cura-sil reactive polymeric back bedding compound at exterior, and heel of glass, full perimeter at panel glazing leg. Glass stop rails part PP-005-0700 at exterior of glass and glazing stop part #PP-009-6000 at the interior of glass.

**Weep Arrangement:** Sloped sill.

**Reinforcement:** None.

**Installation:** Test specimen installed into a nominal 2"x10" test buck with #8 x 3" drywall screws spaced 6" from each end and 18" on center.

**Other Features:** Panel corner construction is coped and butted and attached with 5/8" x 4 9/16" fluted wood dowels and Type 1 Polyvinyl Acetate Catalyzed adhesive. Top rail to stile connected with two (2) fluted wood dowels, and bottom rail to stile connected with four (4) fluted wood dowels.

**7. PERFORMANCE RESULTS**

**Specification: ASTM E 330-02**

<u>Title of Test</u>	<u>Test Method</u>	<u>Measured</u>	<u>Allowed</u>
Uniform Structural	ASTM E 330-02		
-Positive		90.00 PSF	90.00 PSF
-Negative		90.00 PSF	90.00 PSF
-Permanent Set    No Set		0.391"	

**Specification: ASTM E 330-02: ASTM E 1886-04/ASTM E 1996-03 Missile Level Type D, 1996-97 Missile level Type C (#2 yellow pine weighing 9 lbs and measuring 7'-11" overall).**

**Test Specimen 1**

Par No	Speed	Rotation	Title of Test	Measured	Allowable
5.3.1.1	50.1 fps	0°	Center of panel	No Penetration	See Section 4
5.3.2.1	50.0 fps	0°	Upper right corner	No Penetration	See Section 4

Florida Registered Professional Engineers Review: Reg. # 52849, February 28, 2007

Signature: \_\_\_\_\_

*Abdo. Rezaad* 9/26/05



*Abdo. Rezaad* 9/26/05



**ASTM E 1996-1886 PERFORMANCE TESTING**  
**SIMPSON DOOR COMPANY**  
**SERIES 7001 WOOD FRENCH FIXED**  
 REPORT #CCLI-05-128

September 19, 2005  
 Page 4 of 5

**Test Specimen 2**

Par No	Speed	Rotation	Title of Test	Measured	Allowable
5.3.1.2	50.2 fps	0°	Lower left corner	No Penetration	See Section 4
5.3.2.2	50.1 fps	0°	Center of panel	No Penetration	See Section 4

**Test Specimen 3**

Par No	Speed	Rotation	Title of Test	Measured	Allowable
5.3.1.3	51.1 fps	0°	Upper right corner	No Penetration	See Section 4
5.3.3.6	50.2 fps	0°	Center of panel	No Penetration	See Section 4

The laboratory temperature was 86° F for the duration of testing. Test specimens were stored in the lab prior to testing and the skin temperature was recorded at 85° F.

Visual inspections performed on the test specimens revealed there were no penetrations through the laminate and no separation of vision-to-member glazing at the conclusion of the large missile impact tests.

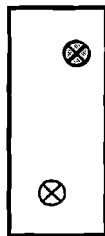

TEST SPECIMEN 1

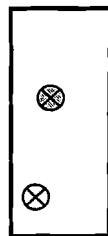

TEST SPECIMEN 2



TEST SPECIMEN 3

⊗ Impact #1      ⊗ Impact #2

**Uniform Static Air Cyclic Test**

**Test Specimens 1, 2, & 3**

Load Direction	Sequence	Range	Cycle Time	Cycles	Damage
60.0 PSF Positive	Cycle 1	0.2 $P_{max}$ to 0.5 $P_{max}$	< 3 seconds	3500	None
	Cycle 2	0 to 0.6 $P_{max}$	< 3 seconds	300	None
	Cycle 3	0.5 $P_{max}$ to 0.8 $P_{max}$	< 3 seconds	600	None
	Cycle 4	0.3 $P_{max}$ to 1.0 $P_{max}$	< 3 seconds	100	None

2-mil polyethylene plastic was duct taped to frame and covered specimens to maintain chamber pressure.

Florida Registered Professional Engineers Review: Reg. # 52849, February 28, 2007 - Abdol Rezadad, P.E.

Signature: Abdol Rezadad 9/26/05

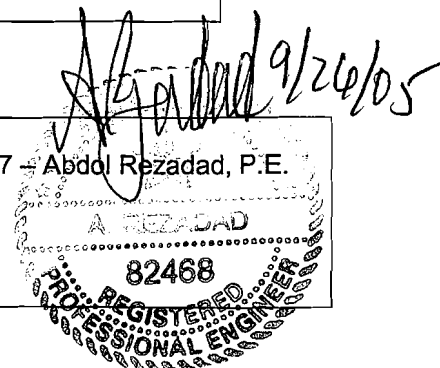



ASTM E 1996-1886 PERFORMANCE TESTING  
**SIMPSON DOOR COMPANY**  
**SERIES 7001 WOOD FRENCH FIXED**  
 REPORT #CCLI-05-128

September 19, 2005  
 Page 5 of 5

Load Direction	Sequence	Range	Cycle Time	Cycles	Damage
60.0 PSF Negative	Cycle 1	0.3 $P_{max}$ to 1.0 $P_{max}$	< 3 seconds	50	None
	Cycle 2	0.5 $P_{max}$ to 0.8 $P_{max}$	< 3 seconds	1050	None
	Cycle 3	0 to 0.6 $P_{max}$	< 3 seconds	50	None
	Cycle 4	0.2 $P_{max}$ to 0.5 $P_{max}$	< 3 seconds	3350	None

2-mil polyethylene plastic was duct taped to frame and covered specimens to maintain chamber pressure. Plastic did not enhance the structural properties of the test specimen.

Visual inspections performed on the test specimens revealed there were no penetrations through the laminate and no separation of vision-to-member glazing at the conclusion of the cyclic pressure differentials.

Detailed extrusion and assembly drawings indicating measured wall thickness and corner construction are on file and have been compared to the test sample submitted. These records will be retained at CCLI for a period of four years.

**8. CONCLUSION**

The test specimens, Simpson Door Company Series 7001 Wood French Fixed, passed the impact resistant criteria of ASTM E 1996 and Cyclic Criteria of ASTM E 1886 at 60.0 psf. The above results were achieved by using the designated test methods and indicate compliance with the above specification. This report does not constitute certification of this product, which may only be granted by the certification program administrator.

Respectfully submitted,

Construction Consulting Laboratory, International

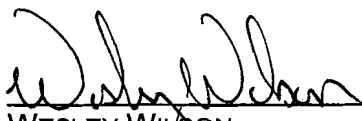
  
 WESLEY WILSON  
 LABORATORY MANAGER

  
 BRANDON NEWMAN  
 TESTING TECHNICIAN

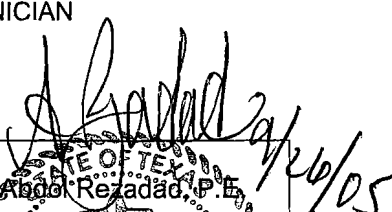
Florida Registered Professional Engineers Review: Reg. # 52849, February 28, 2007 –  A. Rezadad, P.E.

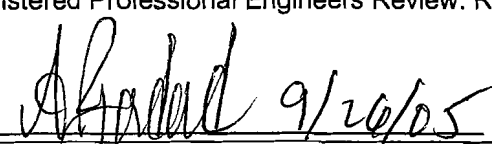
Signature:  9/20/05

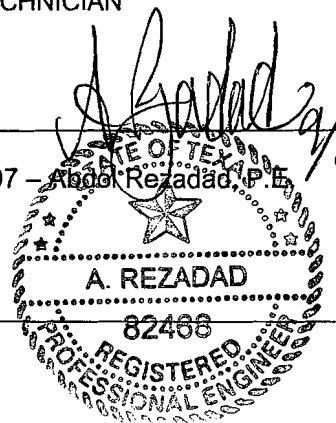



ASTM E 1996-1886 PERFORMANCE TESTING  
**SIMPSON DOOR COMPANY**  
**SERIES 7001 WOOD FRENCH FIXED**  
REPORT #CCLI-05-128

September 19, 2005

## APPENDIXES



## APPENDIX A

### PRODUCT DRAWINGS

<u>Drawings</u>	<u>Part #</u>	<u>Date</u>
COVER		
LAYOUT DETAIL	7001 FIXED DOOR UNIT	8/6/2005
CONFIGURATION OF OPENINGS	7701 HURRICANE TEST SIDE LITE	8/6/2005
ENDURA FIXED SIDE LITE SILL	7001 HURRICANE FIXED LITE	8/6/2005
CONSTRUCTION OF STILE AND RAIL	7001 HURRICANE FIXED LITE	8/6/2005
STILE AND RAIL INTERSECTION	7701 HURRICANE FIXED LITE	8/6/2005
VIEW SAVER WITH ID MARK	PP-005-0700	8/6/2005
VIEW SAVER DOUBLE COPE	PP-001-0701	8/6/2005
GLAZING BEAD	PP-009-6000	8/6/2005
DOOR JAMB CROSS SECTION	7001 HURRICANE FIXED UNIT	8/6/2005
LAMINATED IG MAKEUP	7701 HURRICANE FIXED LITE	8/6/2005
LAMINATED IG ORIENTATION	7001 HURRICANE FIXED LITE	8/6/2005
UNIT ASSEMBLY NOTES	7001 HURRICANE FIXED LITE	8/6/2005
SECTION DETAILS 1/9	7001 HURRICANE FIXED UNIT	8/6/2005
SECTION DETAILS 1/10	7001 HURRICANE FIXED UNIT	8/6/2005
SINGLE FIXED INSTALLATION INSTRUCTIONS		

Submittal Information for Door Unit Evaluation  
to: Texas Department of Insurance for compliance  
evaluation of wind loads specified in the  
International Residential Code (IRC) and the  
International Building Code (IBC).



Simpson Door Co.  
400 Simpson Ave.  
McCleary, WA 98557  
ph. 360-495-3291  
fx. 360-495-2088

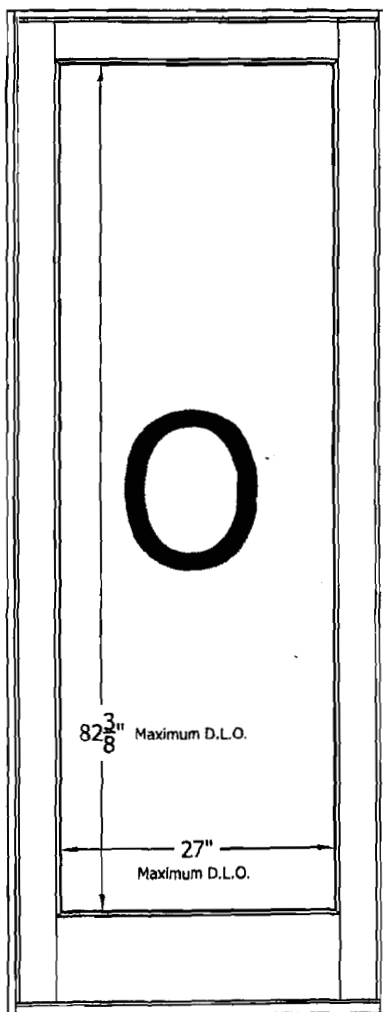

Fixed Unit  
As viewed from interior

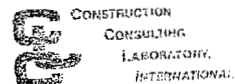

1601 Luma Road  
Carrollton, Texas 75006  
Phone (972) 342-0008  
Report # 2-108 Date 9/19/05  
Reviewed BY [Signature]

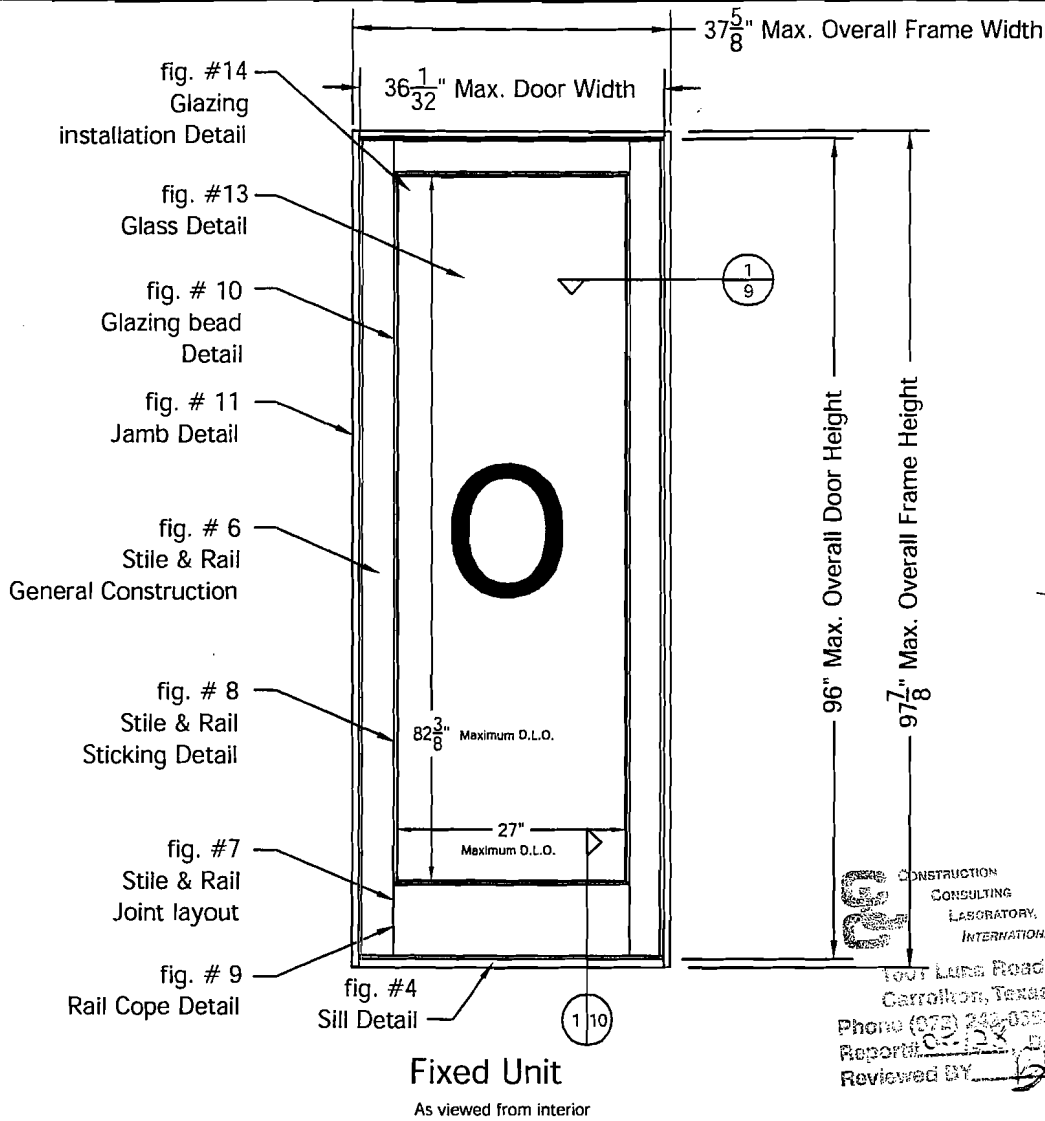

**Submittal Information Table of Contents**

**Table of Contents**

Page #	Description	Page #	Description
1	Cover Page showing general unit look	10	fig. #11 - Jamb cross section
2	fig. #1 - Full light fixed door unit - Tested Elevation	11	fig. #13 - Cardinal Glass Co. Laminated IG Impact Glazing makeup section
3	fig. #2 - Configuration of openings overview	12	fig. #14 - Laminated IG unit installation direction section view
4	fig. #4 - Endura products fixed unit sill cross section	13	fig. #16 - Unit assembly notes
5	fig. #6 - General construction of Stile & Rail rough stock	14	Section Detail 1/9
6	fig. #7 - General construction of Stile & Rail intersection Joints	15	Section Detail 1/10
7	fig. #8 - Simpson Sticking Profile PP-005-0700	16	Unit Assembly notes
8	fig. #9 - Simpson Cope Profile PP-001-0701	17	Installation instructions
9	fig. #10 - Simpson Door Co. - Glazing bead Profile PP-009-6000		

THIS DRAWING AND THE INFORMATION CONTAINED HEREIN IS PROPRIETARY TO SIMPSON DOOR COMPANY AND SHALL NOT BE REPRODUCED, COPIED OR DISCLOSED IN WHOLE OR PART, OR USED FOR MANUFACTURE OR FOR ANY OTHER PURPOSE WITHOUT THE WRITTEN PERMISSION OF SIMPSON DOOR COMPANY.

Revisions

Rev. #	Description	Date	by Whom

TITLE fig. #1 Wood French Fixed Door unit			
DRAWING NO. 7001 Hurricane Test Fixed Door Unit			
LAYOUT 00	SCALE NTS	BORE PATTERN # 7054	
DRAWN BY: S. Beerbower		DATE 8/6/2005	

**Simpson®**

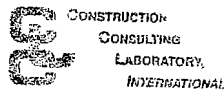
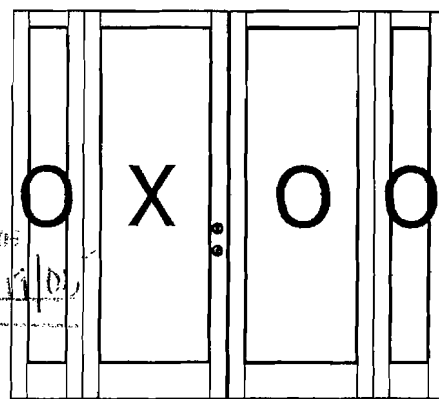
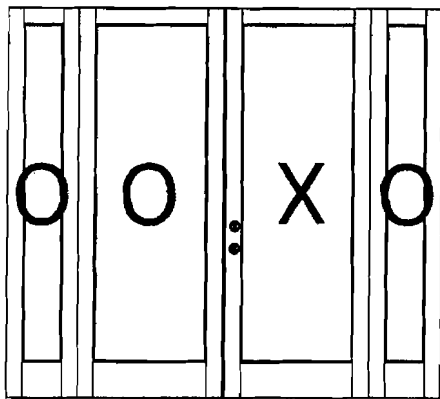
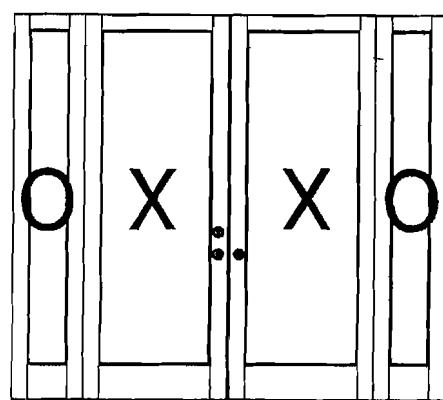
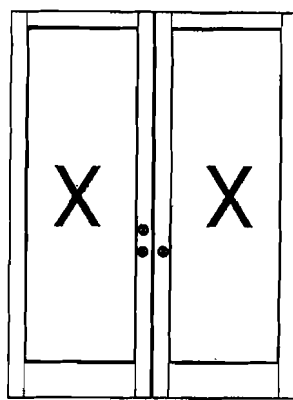
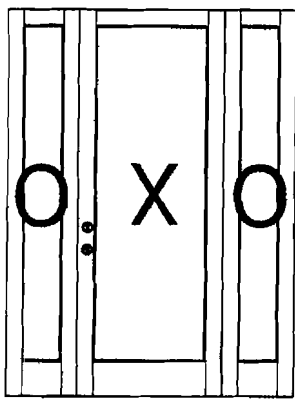
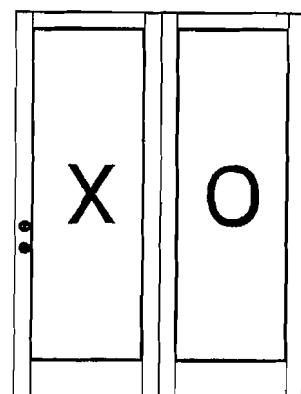
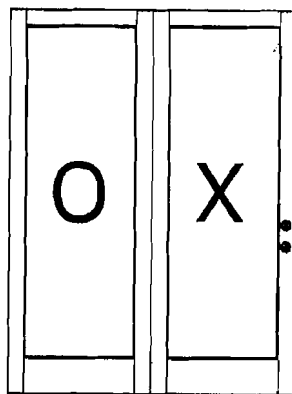
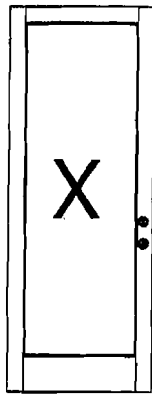
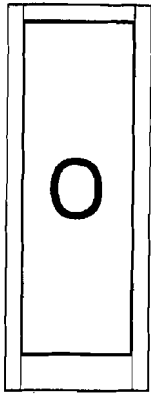

1601 Luna Road  
 Carrollton, Texas 75011  
 Phone (972) 242-8586  
 Report # DL-174, Date 8/6/05  
 Reviewed BY [Signature]

THIS DRAWING AND THE INFORMATION CONTAINED HEREIN IS PROPRIETARY TO SIMPSON DOOR COMPANY AND SHALL NOT BE REPRODUCED, COPIED OR DISCLOSED IN WHOLE OR PART, OR USED FOR MANUFACTURE OR FOR ANY OTHER PURPOSE WITHOUT THE WRITTEN PERMISSION OF SIMPSON DOOR COMPANY.

Revisions

Rev. #	Description	Date	by Whom

TITLE fig. #2  
 Configuration of Openings / Overview

DRAWING NO. 7701 Hurricane Test Sidelight

LAYOUT 00 SCALE NTS BORE PATTERN # 7054

DRAWN BY: S. Beerbower DATE 8/6/2005

**Simpson®**

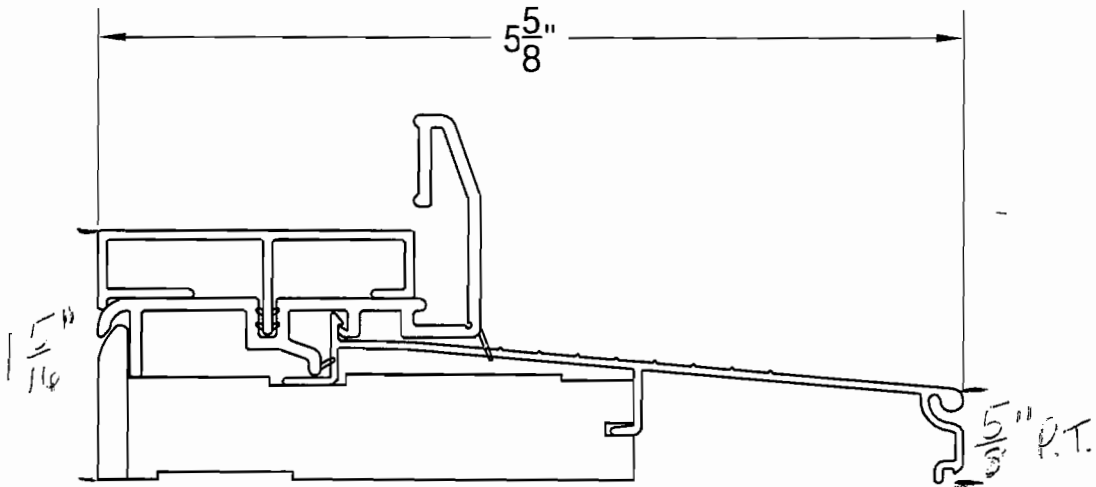

Endura Products, Inc. Model AI5625VH3 with  
Inactive Sidelight Seat installed



CONSTRUCTION  
CONSULTING  
LABORATORY,  
INTERNATIONAL  
1601 Luna Road  
Carrollton, Texas 75006  
Phone (972) 242-0556  
Report# C5-156 Date 4/19/05  
Reviewed BY [Signature]

THIS DRAWING AND THE INFORMATION CONTAINED HEREIN IS PROPRIETARY TO SIMPSON DOOR COMPANY AND SHALL NOT BE REPRODUCED, COPIED OR DISCLOSED IN WHOLE OR PART, OR USED FOR MANUFACTURE OR FOR ANY OTHER PURPOSE WITHOUT THE WRITTEN PERMISSION OF SIMPSON DOOR COMPANY.

TITLE fig. #4  
Endura Products Fixed Sidelight Sill

DRAWING NO. 7001 Hurricane fixed light

LAYOUT 00 SCALE NTS BORE PATTERN # 7054

DRAWN BY: S. Beerbower DATE 8/6/2005



Revisions

Rev. #	Description	Date	by Whom

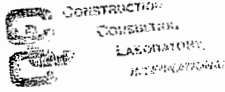

1801 Lull, Floor  
 Carrollton, Texas 75006  
 Phone (972) 440-1000  
 Reports: 05/05  
 Reviewed BY: [Signature]

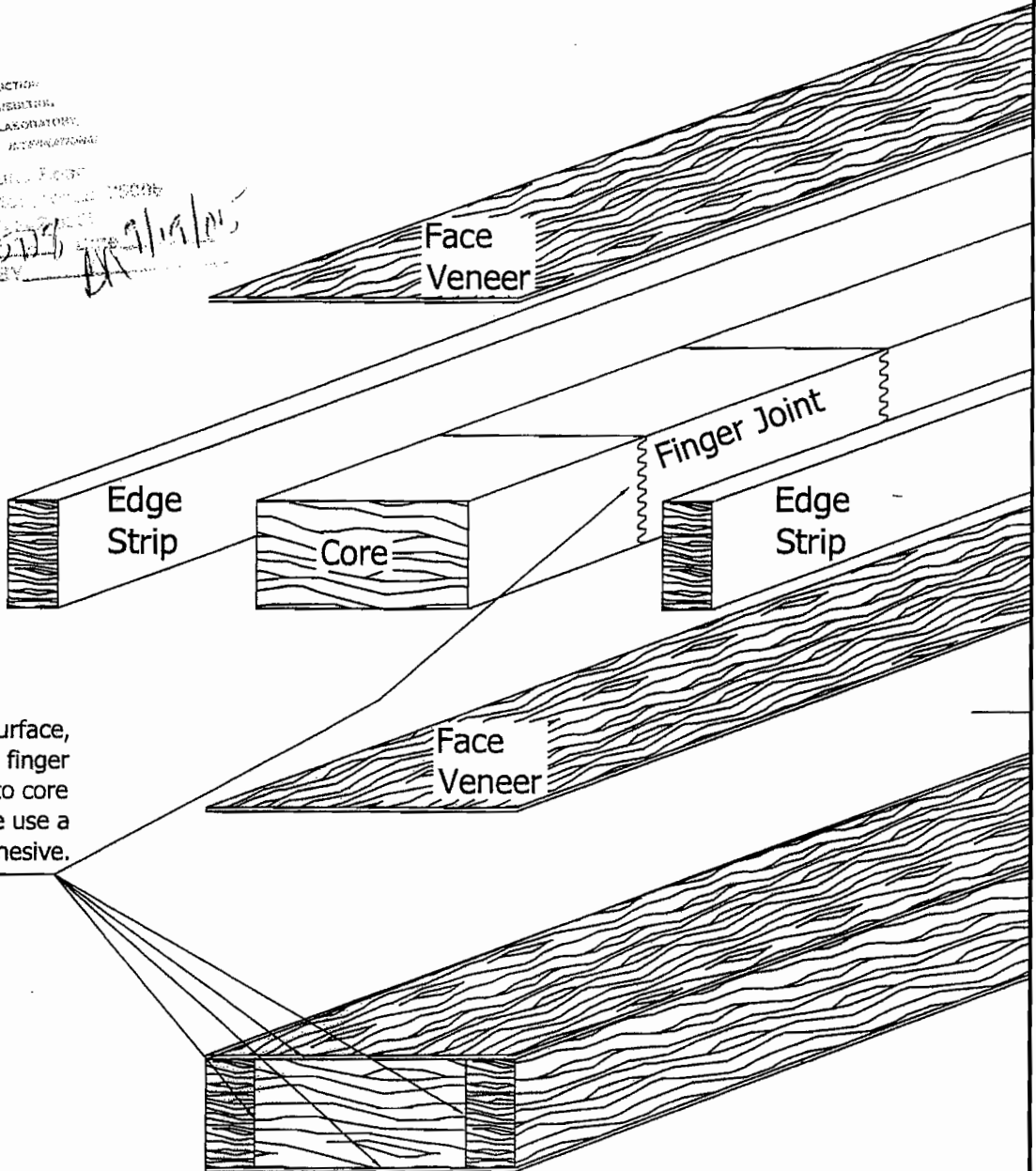

Every Joined surface,  
 core to core via finger  
 joint, Edge strip to core  
 & faces to core use a  
 PVAC "type 1" adhesive.

THIS DRAWING AND THE INFORMATION CONTAINED HEREIN IS PROPRIETARY TO SIMPSON DOOR COMPANY AND SHALL NOT BE REPRODUCED, COPIED OR DISCLOSED IN WHOLE OR PART, OR USED FOR MANUFACTURE OR FOR ANY OTHER PURPOSE WITHOUT THE WRITTEN PERMISSION OF SIMPSON DOOR COMPANY.

TITLE fig. #6  
 General construction of Stile & Rail  
 rough stock

DRAWING NO. 7701 Hurricane Test Sidelight

LAYOUT 00	SCALE NTS	BORE PATTERN # 7054
DRAWN BY: S. Beerbower	DATE 8/6/2005	

**Simpson®**

Revisions			
Rev. #	Description	Date	by Whom

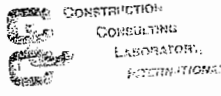

1601 Lund Road  
 Carrollton, Texas 75006  
 Phone (972) 992-1115  
 Report # 03-108 Date 9/15/05  
 Reviewed by DA

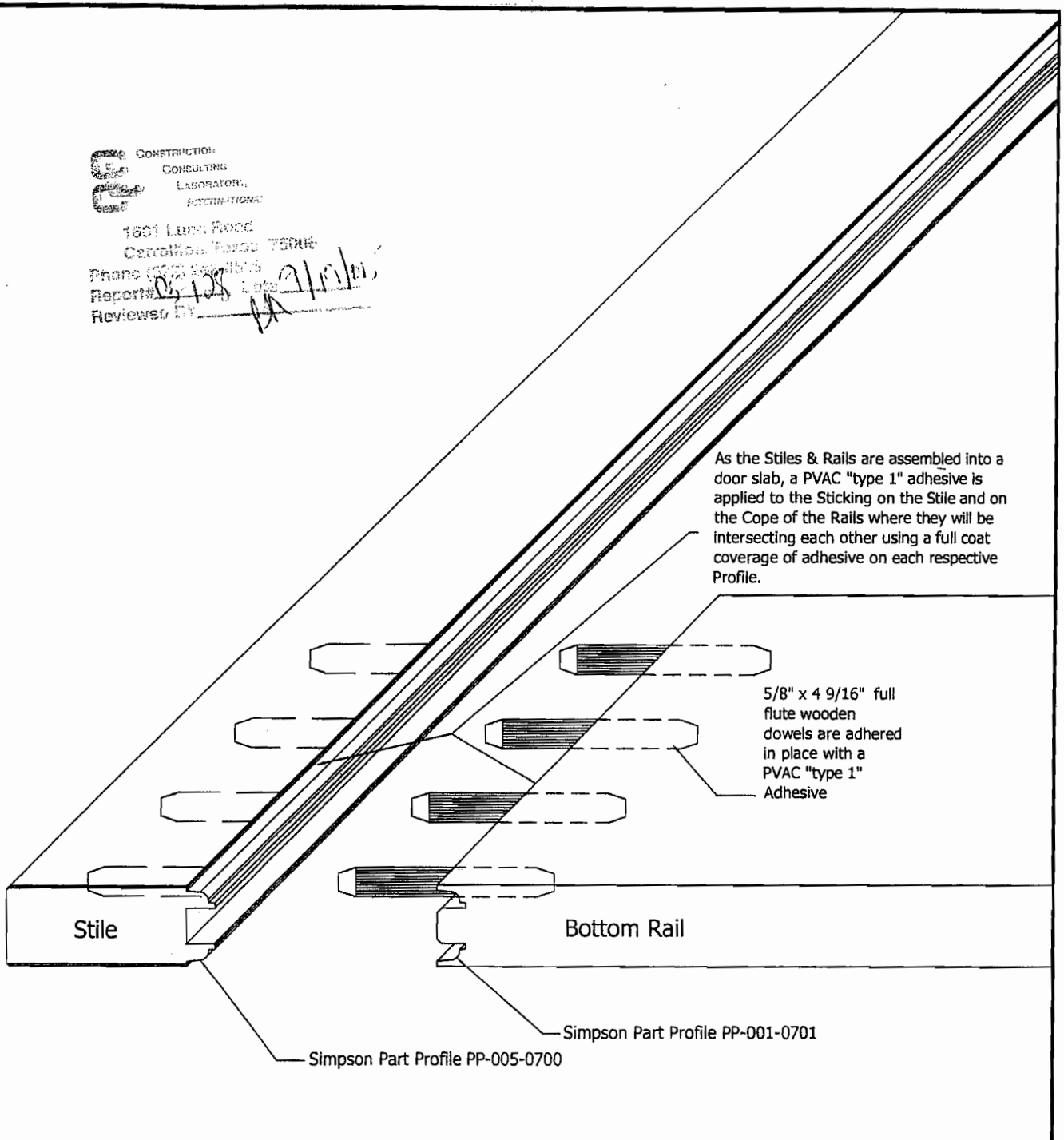

As the Stiles & Rails are assembled into a door slab, a PVAC "type 1" adhesive is applied to the Sticking on the Stile and on the Cope of the Rails where they will be intersecting each other using a full coat coverage of adhesive on each respective Profile.

5/8" x 4 9/16" full flute wooden dowels are adhered in place with a PVAC "type 1" Adhesive

Stile

Bottom Rail

Simpson Part Profile PP-001-0701

Simpson Part Profile PP-005-0700

THIS DRAWING AND THE INFORMATION CONTAINED HEREIN IS PROPRIETARY TO SIMPSON DOOR COMPANY AND SHALL NOT BE REPRODUCED, COPIED OR DISCLOSED IN WHOLE OR PART, OR USED FOR MANUFACTURE OR FOR ANY OTHER PURPOSE WITHOUT THE WRITTEN PERMISSION OF SIMPSON DOOR COMPANY.

Revisions

Rev. #	Description	Date	by Whom

TITLE <b>fig. #7</b> Stile & Rail Joint intersection joint			
DRAWING NO. 7701 Hurricane Test Sidelight			
LAYOUT 00	SCALE NTS	BORE PATTERN # 7054	
DRAWN BY: S. Beerbower		DATE 8/6/2005	



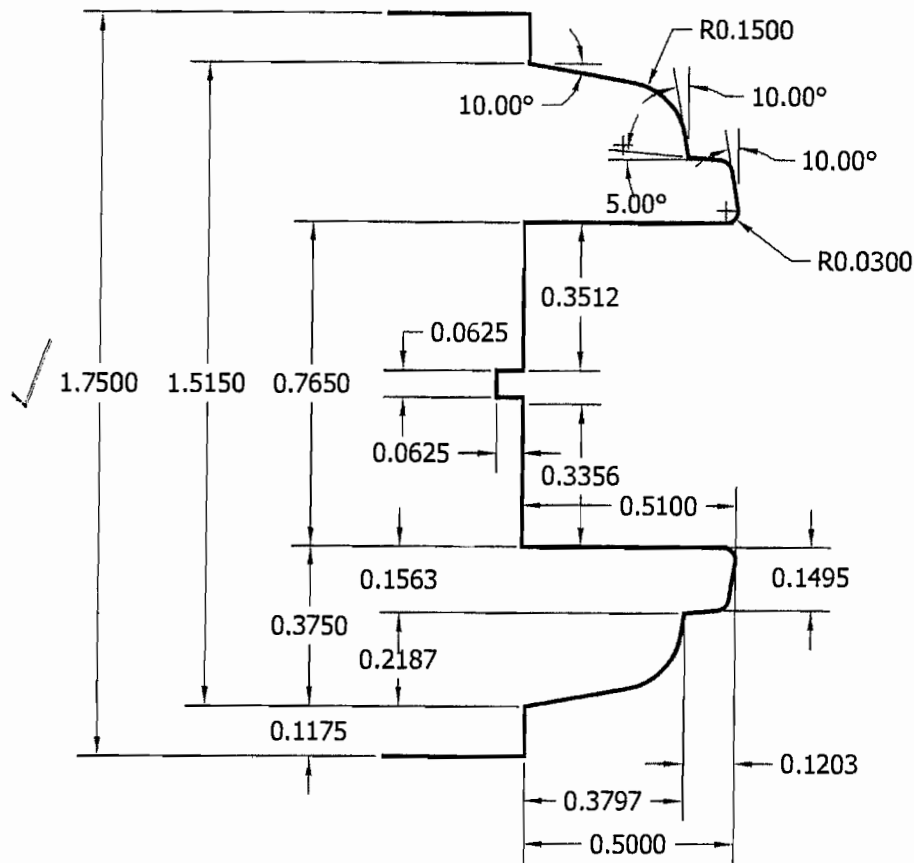

This Detail is used on the edges of the Door Stiles and Rails that face into the glazing opening.

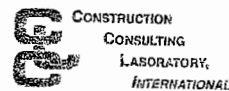

CONSTRUCTION  
CONSULTING  
LABORATORY,  
INTERNATIONAL  
1601 Luna Road  
Carrollton, Texas 75006  
Phone (972) 242-0356  
Report# 02-128, Date 4/19/05  
Reviewed BY [Signature]

THIS DRAWING AND THE INFORMATION CONTAINED HEREIN IS PROPRIETARY TO SIMPSON DOOR COMPANY AND SHALL NOT BE REPRODUCED, COPIED OR DISCLOSED IN WHOLE OR PART, OR USED FOR MANUFACTURE OR FOR ANY OTHER PURPOSE WITHOUT THE WRITTEN PERMISSION OF SIMPSON DOOR COMPANY.

Revisions

Rev. #	Description	Date	by Whom

TITLE		fig. #8	
		View Saver® Double Sticking w/ID Mark	
DRAWING NO. PP-005-0700			
LAYOUT	00	SCALE	NTS
DRAWN BY:	S. Beerbower	DATE	5/31/2005
<b>Simpson®</b>			

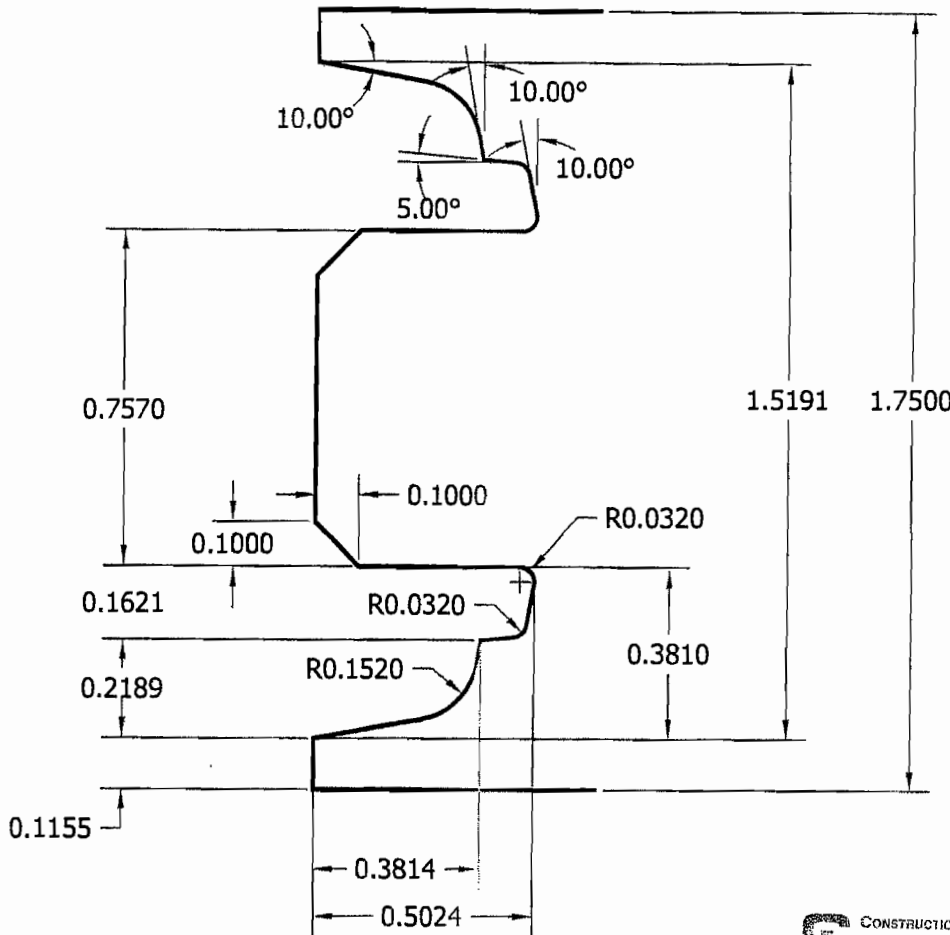

This detail is used on the ends of the Door rails.

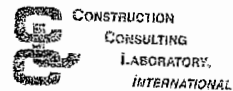

CONSTRUCTION  
CONSULTING  
LABORATORY  
INTERNATIONAL  
1601 Luna Road  
Carrollton, Texas 75006  
Phone (972) 242-0556

Report # 128 Date 7/19/05  
Reviewed BY [Signature]

THIS DRAWING AND THE INFORMATION CONTAINED HEREIN IS PROPRIETARY TO SIMPSON DOOR COMPANY AND SHALL NOT BE REPRODUCED, COPIED OR DISCLOSED IN WHOLE OR PART, OR USED FOR MANUFACTURE OR FOR ANY OTHER PURPOSE WITHOUT THE WRITTEN PERMISSION OF SIMPSON DOOR COMPANY.

Revisions

Rev. #	Description	Date	by Whom

TITLE fig. #9 View Saver® Double Cope			
DRAWING NO. PP-001-0701			
LAYOUT 00	SCALE NTS		
DRAWN BY: S. Beerbower	DATE 5/31/2005		
<b>Simpson®</b>			

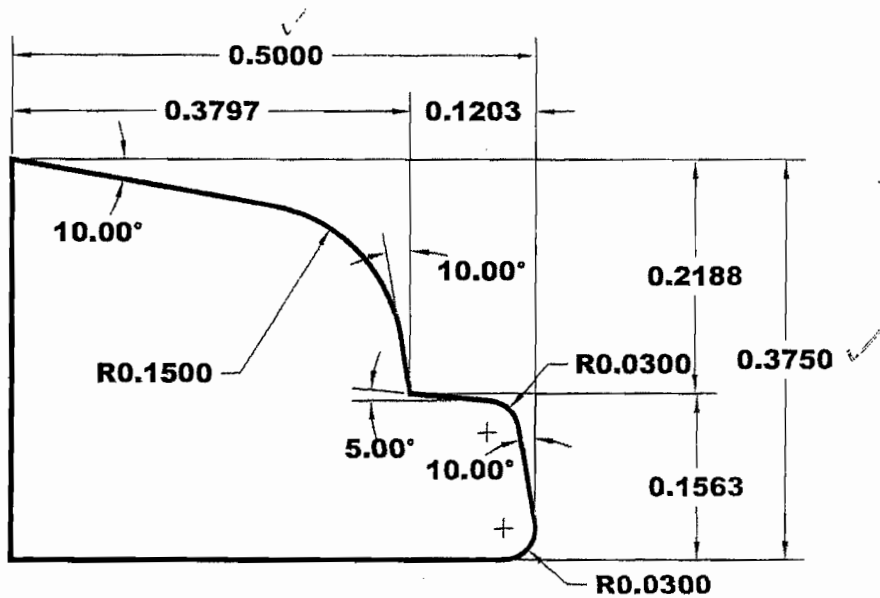

This Detail is of the Glazing bead (stop) that holds the glazing into the door unit. The Glazing bead is secured with Pneumatic driven brads 1" long by 18 gauge diameter placed at a spacing of 6 to 8 inches with a brad being placed within 3" of the end of any bead.

**CE** CONSTRUCTION  
CONSULTING  
LABORATORY  
INTERNATIONAL

1601 Luna Road  
Carrollton, Texas 75006  
Phone (972) 242-0556  
Report # 05-128 Date 7/19/05  
Reviewed BY JA

THIS DRAWING AND THE INFORMATION CONTAINED HEREIN IS PROPRIETARY TO SIMPSON DOOR COMPANY AND SHALL NOT BE REPRODUCED, COPIED OR DISCLOSED IN WHOLE OR PART, OR USED FOR MANUFACTURE OR FOR ANY OTHER PURPOSE WITHOUT THE WRITTEN PERMISSION OF SIMPSON DOOR COMPANY.

TITLE fig. #10  
View Saver® Replacement Sticking &  
Glazing bead

DRAWING NO. PP-009-6000

LAYOUT	00	SCALE	NTS	BORE PATTERN #	N/A
DRAWN BY:	S. Beerbower			DATE	8/6/2005

**Simpson®**

Revisions

Rev. #	Description	Date	by Whom

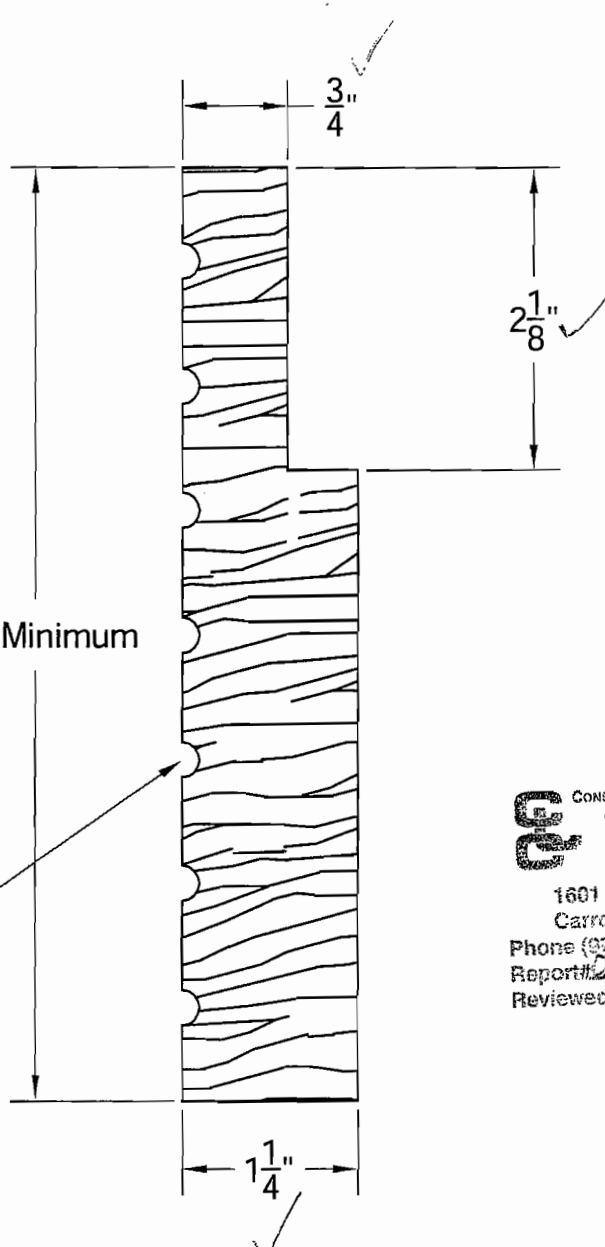

Note:  
 Frame components are kerfed along the back side to provide relief from wood stresses and help in the prevention of bowing or warping of the frame.

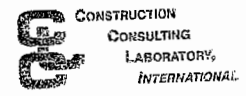

1601 Luna Road  
 Carrollton, Texas 75006  
 Phone (972) 242-9556  
 Report# 2-128 Date 8/19/05  
 Reviewed BY [Signature]

THIS DRAWING AND THE INFORMATION CONTAINED HEREIN IS PROPRIETARY TO SIMPSON DOOR COMPANY AND SHALL NOT BE REPRODUCED, COPIED OR DISCLOSED IN WHOLE OR PART, OR USED FOR MANUFACTURE OR FOR ANY OTHER PURPOSE WITHOUT THE WRITTEN PERMISSION OF SIMPSON DOOR COMPANY.

TITLE fig. #11 Door Jamb cross section		
DRAWING NO. 7001 Hurricane Test Fixed Door Unit		
LAYOUT 00	SCALE NTS	BORE PATTERN # 7054
DRAWN BY: S. Beerbower	DATE 8/6/2005	

Revisions			
Rev. #	Description	Date	by Whom



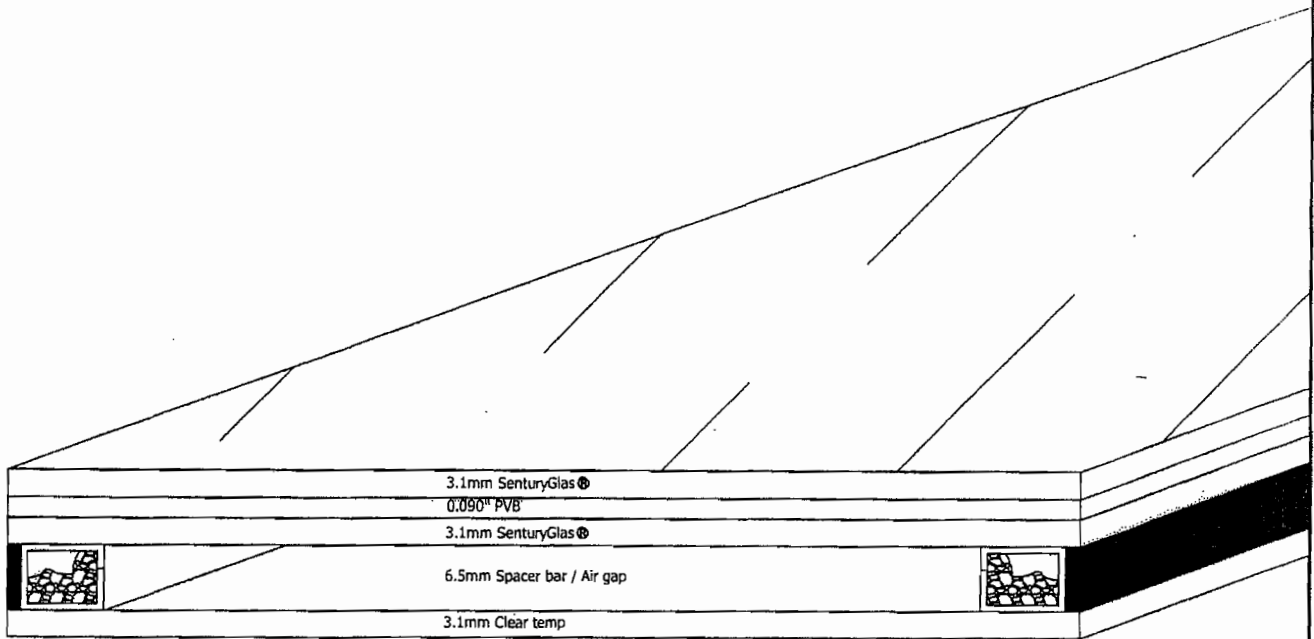

Cardinal IG Co. Glazing Material.

IG Unit makeup is as follows:

3.1 mm Clear temp, 6.5 mm Spacer bar, 8.6mm Laminated sheet.

Laminated sheet makeup is as follows:

3.1mm SentryGlas®, 0.090\"/>

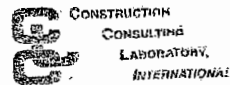

1601 Luna Road  
 Carrollton, Texas 75006  
 Phone (972) 242-8866  
 Report # 05-178 Date 9/19/05  
 Reviewed by [Signature]

THIS DRAWING AND THE INFORMATION CONTAINED HEREIN IS PROPRIETARY TO SIMPSON DOOR COMPANY AND SHALL NOT BE REPRODUCED, COPIED OR DISCLOSED IN WHOLE OR PART, OR USED FOR MANUFACTURE OR FOR ANY OTHER PURPOSE WITHOUT THE WRITTEN PERMISSION OF SIMPSON DOOR COMPANY.

Revisions

Rev. #	Description	Date	by Whom

TITLE fig. #13 Laminated IG unit makeup			
DRAWING NO. 7701 Hurricane Test Sidelight			
LAYOUT 00	SCALE NTS	BORE PATTERN # 7054	
DRAWN BY: S. Beerbower		DATE 8/6/2005	
<b>Simpson®</b>			

# Exterior

Simpson Part Profile PP-005-0700  
 Schnee Moorehead SM2100 Back Bedding  
 Schnee Moorehead SM2100 Bedding  
 Schnee Moorehead SM2100 Bedding  
 Glazing Stop, Profile # PP-009-6000

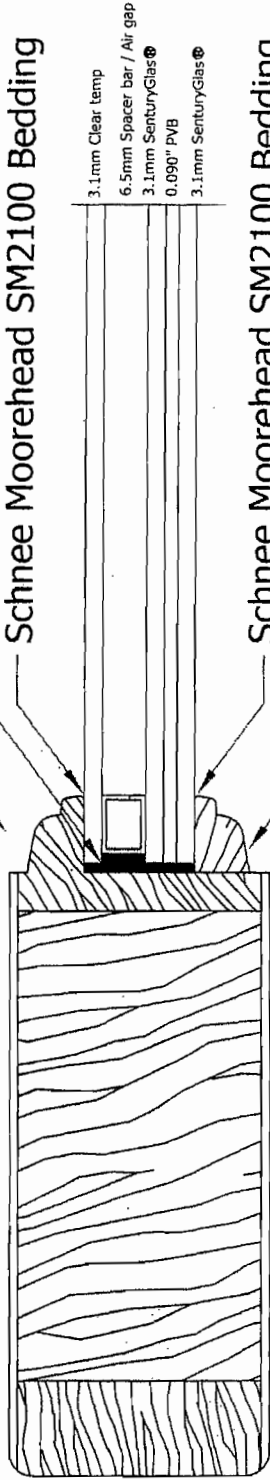

# Interior

THIS DRAWING AND THE INFORMATION CONTAINED HEREIN IS PROPRIETARY TO SIMPSON DOOR COMPANY AND SHALL NOT BE REPRODUCED, COPIED OR DISCLOSED IN WHOLE OR IN PART, OR USED FOR MANUFACTURE OR FOR ANY OTHER PURPOSE WITHOUT THE WRITTEN PERMISSION OF SIMPSON DOOR COMPANY.

**CFE** CONSTRUCTION CONSULTING LABORATORY INTERNATIONAL  
 1601 Linn Road  
 Carrollton, Texas 75006  
 Phone (972) 244-0000  
 Report# 02-108 Date 11/21/05  
 Reviewed By BR

TITLE		fig. #14	
Laminated IG unit installation orientation			
DRAWING NO.	7701	Hurricane Test Sidelight	
LAYOUT	00	SCALE	NTS
BORE PATTERN #	7054		
DRAWN BY:	S. Beerbower	DATE	8/6/2005



Rev. #	Description	Date	by Whom

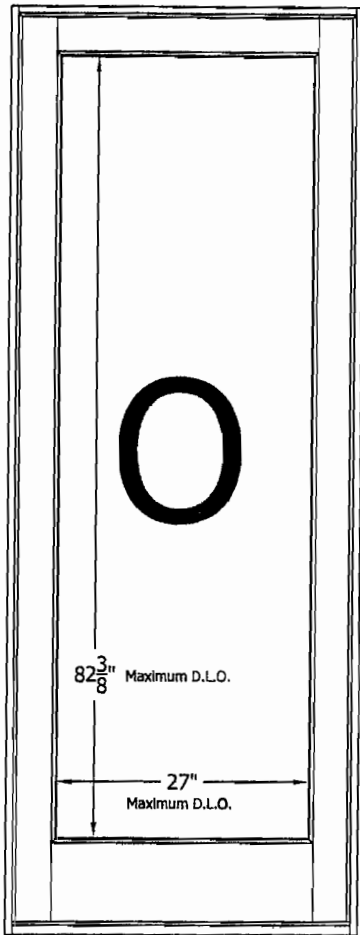

Each Jamb to header (2 typ.) are to have a caulking sealer applied to joint before assembly. Each joint is to be fastened with four each 2" long 3/4" crown gun driven staples.

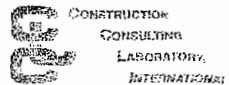

1901 Luna Road  
 Carrollton, Texas 75006  
 Phone (972) 241-6606  
 Report # 05-128 Date 9/19/05  
 Reviewed BY [Signature]

**Fixed Unit**  
 As viewed from interior

Each Jamb to Sill joints (2 typ.) are to have caulking sealer applied to joint before assembly. Each joint is to be fastened with four each 2" long 3/4" crown gun driven staples.

THIS DRAWING AND THE INFORMATION CONTAINED HEREIN IS PROPRIETARY TO SIMPSON DOOR COMPANY AND SHALL NOT BE REPRODUCED, COPIED OR DISCLOSED IN WHOLE OR PART, OR USED FOR MANUFACTURE OR FOR ANY OTHER PURPOSE WITHOUT THE WRITTEN PERMISSION OF SIMPSON DOOR COMPANY.

Revisions

Rev. #	Description	Date	by Whom

TITLE fig. #16 Unit Assembly notes		
DRAWING NO. 7701 Hurricane Test Sidelight		
LAYOUT 00	SCALE NTS	BORE PATTERN # 7054
DRAWN BY: S. Beerbower	DATE 8/6/2005	



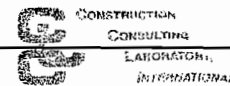
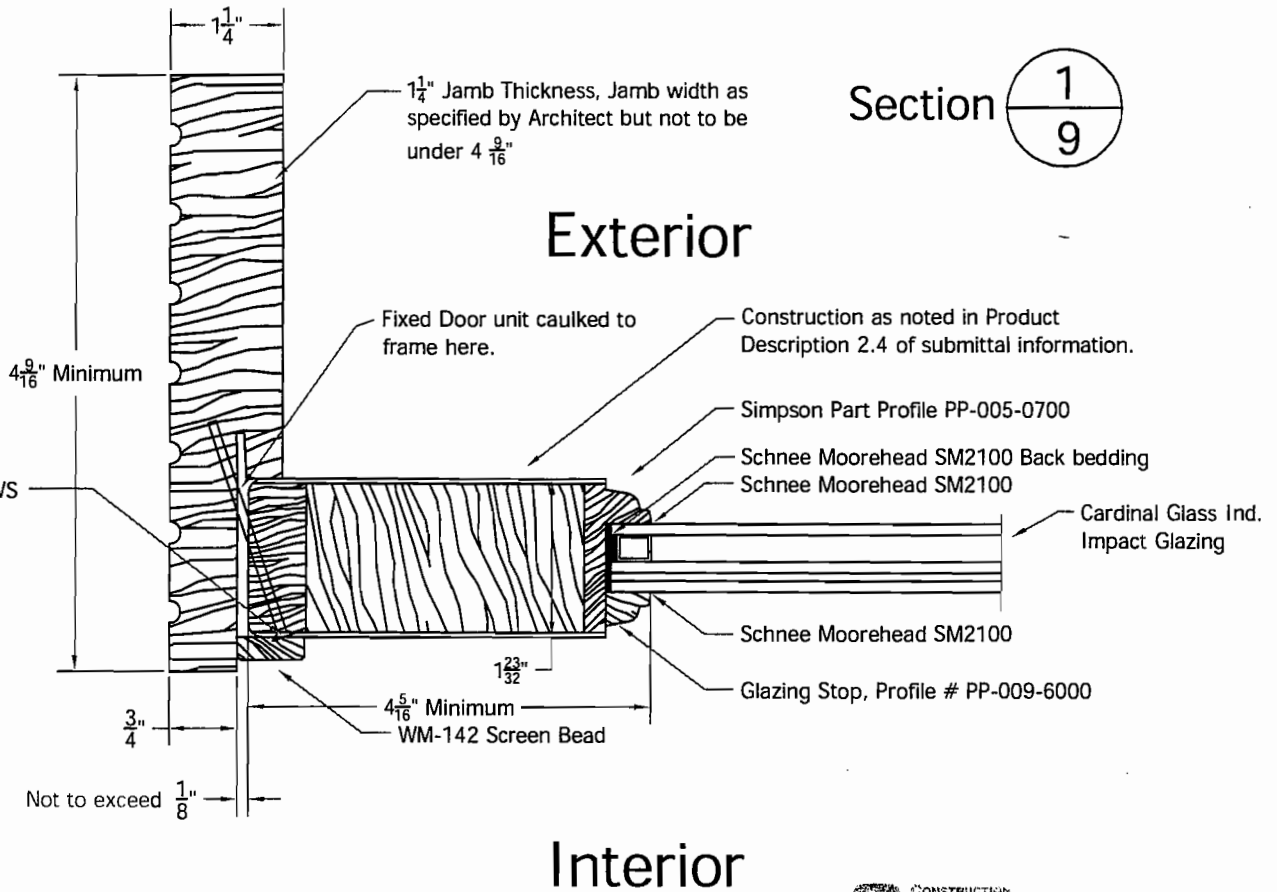

1601 Leno Road  
 Carrollton, Texas 75006  
 Phone (972) 242-0000  
 Report # 05-1286 Date 9/19/05  
 Reviewed BY [Signature]

THIS DRAWING AND THE INFORMATION CONTAINED HEREIN IS PROPRIETARY TO SIMPSON DOOR COMPANY AND SHALL NOT BE REPRODUCED, COPIED OR DISCLOSED IN WHOLE OR PART, OR USED FOR MANUFACTURE OR FOR ANY OTHER PURPOSE WITHOUT THE WRITTEN PERMISSION OF SIMPSON DOOR COMPANY.

TITLE Fixed Sections  
 Section Details 1/9

DRAWING NO. 7001 Hurricane Test Fixed Door Unit

LAYOUT 00 SCALE NTS BORE PATTERN # 7054

DRAWN BY: S. Beerbower DATE 8/6/2005



Revisions

Rev. #	Description	Date	by Whom

Section 1  
10

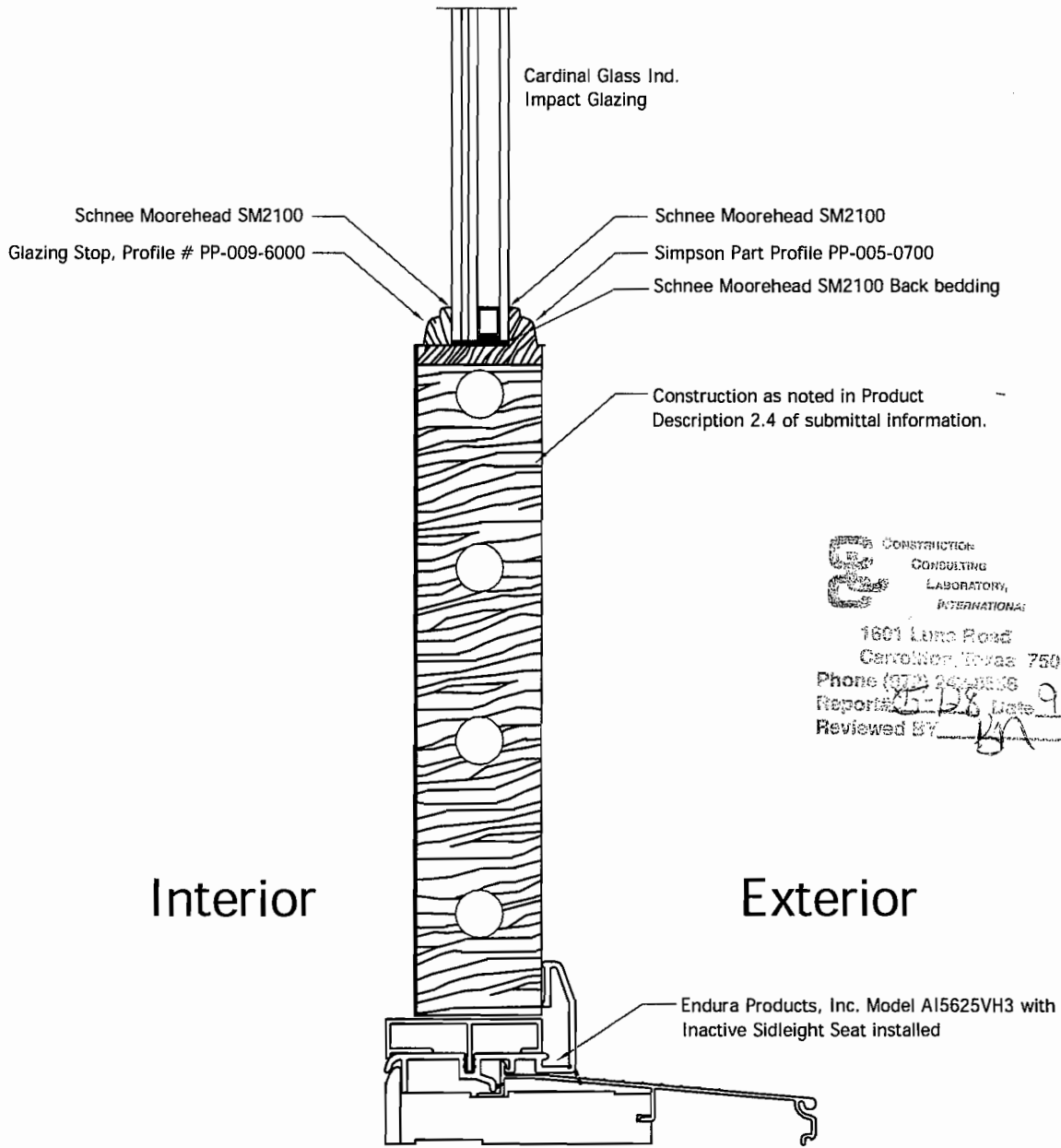

**CONSTRUCTION CONSULTING LABORATORY INTERNATIONAL**  
 1601 Lingo Road  
 Carrollton, Texas 75006  
 Phone (972) 242-2226  
 Report # 07-28 Date 9/19/05  
 Reviewed BY BA

Interior

Exterior

THIS DRAWING AND THE INFORMATION CONTAINED HEREIN IS PROPRIETARY TO SIMPSON DOOR COMPANY AND SHALL NOT BE REPRODUCED, COPIED OR DISCLOSED IN WHOLE OR PART, OR USED FOR MANUFACTURE OR FOR ANY OTHER PURPOSE WITHOUT THE WRITTEN PERMISSION OF SIMPSON DOOR COMPANY.

Revisions

Rev. #	Description	Date	by Whom

TITLE Fixed Sections Section Details 1/10			
DRAWING NO. 7001 Hurricane Test Fixed Door Unit			
LAYOUT 00	SCALE NTS	BORE PATTERN # 7054	
DRAWN BY: S. Beerbower		DATE 8/6/2005	

**Simpson®**

## Single Fixed Assembly and Installation Instructions

### 1) Assembly Information

#### a) Frame Assembly

- A Construct frames, header & sill using 2" long by 3/4" wide crown gun-driven staples.
- B Assembly of the frame set is by butted corner & coped corner construction.
  - (1) Start the assembly of the frame set at the head.
  - (2) Caulk in-between the butted joints where the frame legs meet with the header.
  - (3) Secure the joint using four each 2" long by 3/4" wide crown gun-driven staples at each joint making sure the header fits tight against the frame when stapled together.
  - (4) Remove excess caulking squeeze-out from joint area.
  - (5) Caulk ends of sill and the insides of the coped frame legs where the sill mounts.
  - (6) Position sill inside frame legs at the appropriate position making sure the bottom of the sill is flush with the frame leg before stapling together.
  - (7) Secure the joint using four each 2" long by 3/4" wide crown gun-driven staples at each coped sill joint making sure of a tight fit between sill & frame leg.
  - (8) Remove excess caulking squeeze-out from area.

#### b) Door Placement

- A Lay the frame down on a table, rabbet side up, and caulk the perimeter of the frame rabbet with good quality exterior latex or silicone caulk.
- B Seal the bottom of the door slab from edge to edge and end to end with a quality caulking/sealer and attach Endura sill seat to the bottom edge of the door with 1/2" crown gun driven staples.
- C Set door slab into the frame against the caulk bead and press firmly into place. Remove any excess caulk.
- D Drill 1/8" holes in the face of the slab along both stiles within 3/4" of the edge, on angle to receive #9 x 2-1/2" FHWS through the stile and into the door frame legs. Countersink the head below the surface level of the slab. Set screws approximately 6" - 8". Do not install screws into the head or sill.
- E Cover the screw holes with a profiled screen bead the full perimeter of the door slab.

#### c) Installing the Unit in the Rough Opening

- A Check to be certain the rough opening is square, plumb, level and in the same plane. Use lumber that is structurally sound and not twisted.
- B Place a 3/8" bead of good quality exterior grade silicone caulk on the sub-floor for the full width of the opening allowing the corners at each end to be flooded with caulking. Bring the caulking up the framing studs a minimum of 8".
- C Carefully set the assembled unit into the opening on top of the caulking.
- D Shim the unit to be certain it is square within the rough opening.
- E Install the unit using #9 x 2-1/2" FHWS through each frame leg and shim set securing the frame to the framing studs with a minimum 1-1/2" penetration into the wood.
  - (1) For a 6'8" tall unit, use a minimum of three (3) screws on each frame leg.
  - (2) For a 8'0" tall unit, use a minimum of four (4) screws on each frame leg.
- F Insulate around the unit and apply the finish trim of your choice.



ASTM E 1996-1886 PERFORMANCE TESTING  
**SIMPSON DOOR COMPANY**  
**SERIES 7001 WOOD FRENCH FIXED**  
REPORT #CCLI-05-128

September 19, 2005

**- END OF REPORT -**